

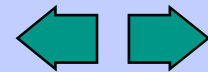

# Power Amplifiers for GSM and eGSM Handsets



# TST0900 Series GSM Power Amplifiers

## Key Features:

- **Single supply voltage; 3 / 5 Volt**
- **32 / 35 dBm output power**
- **High efficiency : 40 / 45 %**
- **Built-in gain control and DC/DC converter**
- **Low cost**

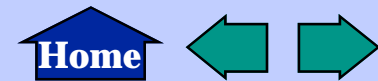

# Basic Application

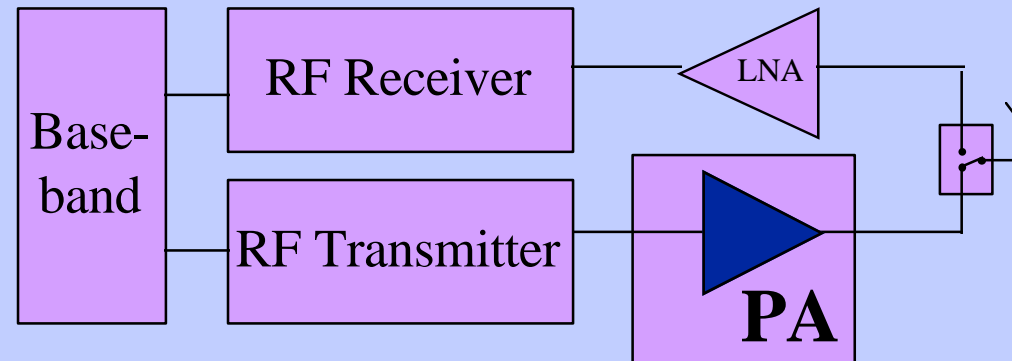

## Products

<b>Device</b>	<b>TST0900</b>	<b>TST0901</b>	<b>TST0902</b>
<b>Supply voltage</b>	<b>4,8 V</b>	<b>3,3 V</b>	<b>3,3 V</b>
<b>Output power</b>	<b>35 dBm</b>	<b>35 dBm</b>	<b>32 dBm</b>
<b>Current consumption</b>	<b>1,5 A</b>	<b>2,5 A</b>	<b>2,0 A</b>

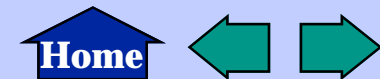

Sales Background

# Elements of the PA

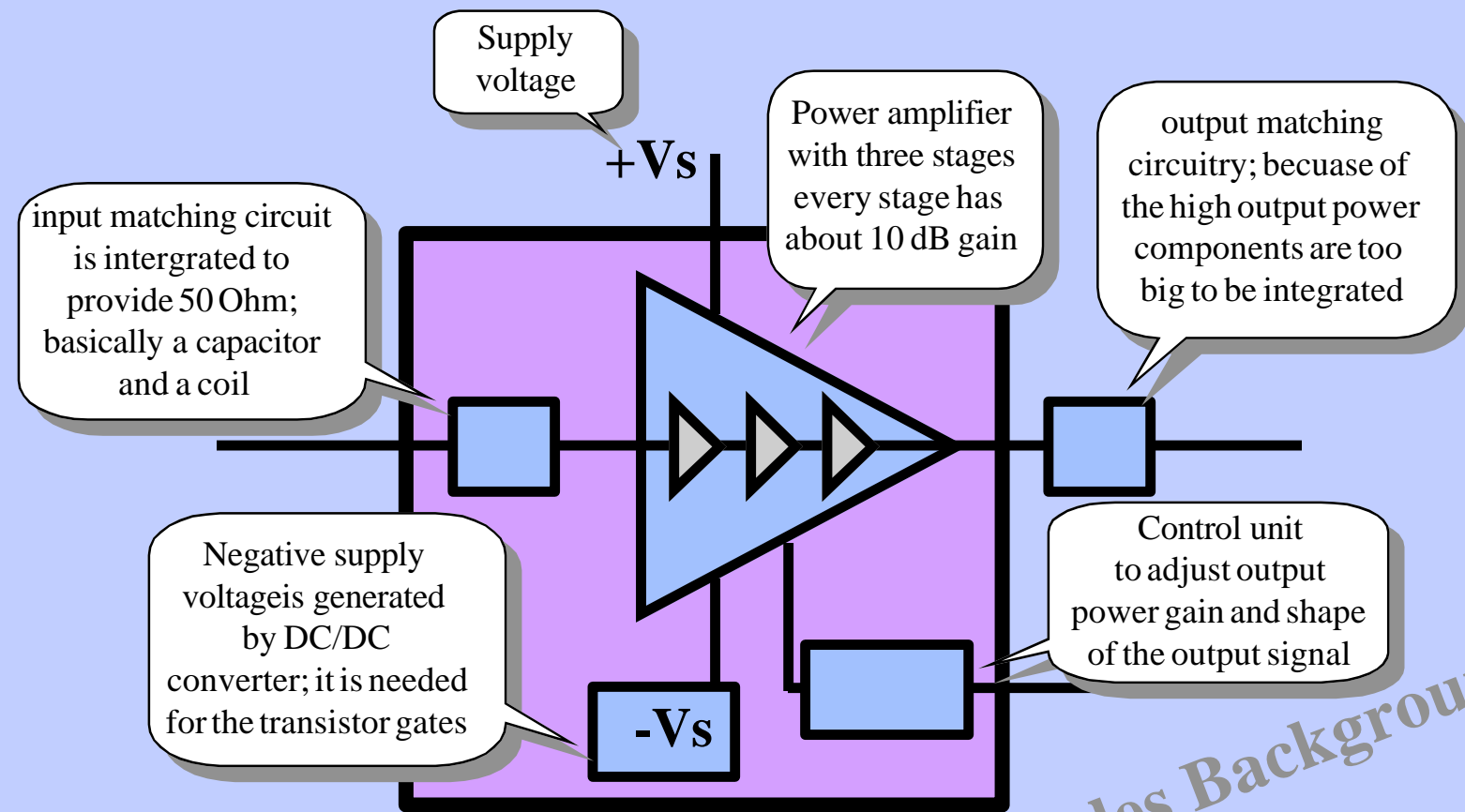

Sales Background

Home ← →

# Realizing GSM using TEMIC Transmit ICs (U2893B and TST090x)

**e-GSM**

**U2893B**

**TST090x**

